

# 20-H Rule Modeling and Measurements

**Hwan W. Shim, Todd H. Hubing**

Electromagnetic Compatibility Laboratory  
 Department of Electrical and Computer Engineering  
 University of Missouri - Rolla  
 Rolla, MO, 65409

**Abstract:** The 20-H rule is a printed circuit board layout guideline. On boards with power and ground planes, the fringing field at the edges of the board is contained by backing the edge of the power plane away from the edge of the board by a distance equal to 20 times the separation distance between the planes. In this study, test boards were built and measured with and without implementing the 20-H rule. The measured results are compared to numerical models. The results of this study show that, although the near fields are more contained, the radiation from a board implementing the 20-H rule is actually slightly higher than the radiation from boards with a traditional design.

## INTRODUCTION

The 20-H rule, first proposed by W. Michael King and described in the book by Mark I. Montrose [1], is a design guideline for laying out printed circuit boards with power and ground planes. The rule states that the edges of the power plane should be set back from the edges of the ground plane by a distance equal to 20 times the vertical spacing between the planes. The idea behind this rule is that fringing fields around the edge will be better contained. It has also been suggested that the radiation from this geometry will be lower compared to the radiation from a board where both planes are the same size [1][3].

In this report, the radiated emissions from two unpopulated boards are compared with and without implementing the 20-H rule. An intuitive analysis based on microstrip patch radiation models is presented and compared to numerical modeling results and measurements.

## THE TEST BOARDS

Two double-sided 7'x 9' test boards with a 30-mil thickness were built for this study. The only difference between the two boards was that the 20-H rule was implemented on one board, while the power plane of the other board was the same size as the ground plane. To inject a signal into the board, an SMA connector was placed a half-inch away from the center point. Figure 1 shows the physical layout of the board implementing the 20-H rule. The edges of power plane were set back from the edges of the ground plane by 0.6", which was 20 times the dielectric thickness. The relative permittivity of the dielectric was 3.85. The other board had basically the same geometry except that the size of two planes was equal.

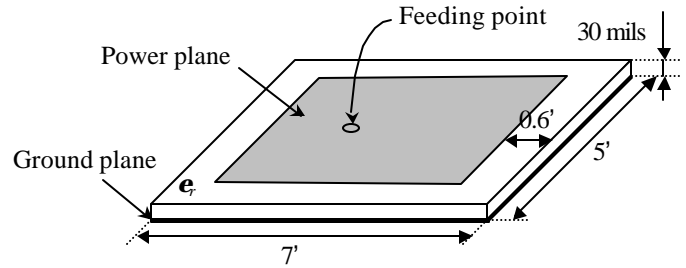

Figure 1. Geometry of the test board implementing the 20-H rule

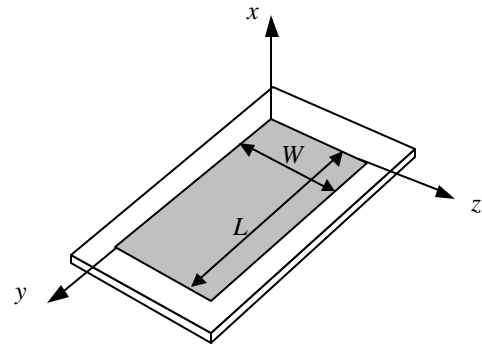

Figure 2. Geometry of a typical rectangular patch antenna and coordinates for analysis

## THEORETICAL ANALYSIS OF THE BOARDS

To calculate the radiated field, the test boards were modeled as rectangular patch antennas. Though a 20-H-rule board has a relatively small ground plane compared to a normal patch antenna, it can be modeled as a patch antenna as long as its fringing fields are contained within the dielectric layer. Using image theory, a normal board can also be modeled as a patch antenna.

Figure 2 shows a typical rectangular patch antenna. Using a resonant cavity model, the electric and magnetic fields between the power and ground planes are given as [2],

$$E_x(y, z) = -j\omega C \cos k_y y \cos k_z z \quad (1)$$

$$H_y(y, z) = Ck_z \cos k_y y \cdot \sin k_z z \quad (2)$$

$$H_z(y, z) = -Ck_y \sin k_y y \cdot \cos k_z z \quad (3)$$

where,

$$k^2 = k_y^2 + k_z^2 = \mathbf{w}^2 \mathbf{m} \mathbf{e} \quad (4)$$

$$k_y = \frac{m\mathbf{P}}{L}, \quad m: 0, 1, 2, 3, \dots \quad (5)$$

$$k_z = \frac{n\mathbf{P}}{W}, \quad n: 0, 1, 2, 3, \dots \quad (6)$$

$C$  = arbitrary constant.

Since all the magnetic fields are perpendicular to the  $x$ -axis, the fields expressed above create transverse magnetic modes to the  $x$ -axis (TM<sup>x</sup>). Resonant frequencies for the TM<sup>x</sup><sub>mn</sub> modes can be obtained using Equation (4) and are given by,

$$f_{mn}^r = \frac{1}{2\mathbf{P}\sqrt{\mathbf{m} \mathbf{e}_{\text{eff}}}} \sqrt{\left(\frac{m\mathbf{P}}{L_e}\right)^2 + \left(\frac{n\mathbf{P}}{W_e}\right)^2} \quad (7)$$

$\mathbf{e}_{\text{eff}}$ ,  $L_e$  and  $W_e$  are mean effective values for  $\mathbf{e}$ ,  $L$  and  $W$ , respectively. Since the length and width of the test boards are much greater than the thickness, effective values of these parameters are approximately equal to the nominal values. Using Equation (7), the resonant frequencies for the test boards can be calculated and are listed in Table 1.

**Table 1. Resonant Frequencies of the Test Boards [MHz]**

	TM10	TM01	TM11	TM20	TM21
Bare Board	334	429	544	668	794
20-H Board	388	522	650	775	934

### Radiated Fields

According to patch antenna theory, only the fringing fields at the ends of the patch ( $y = 0, L$  for TM10 mode and  $x = 0, W$  for TM01 mode) contribute to far-field radiation at the fundamental resonant frequency.

If the test board is sufficiently thin with respect to a wavelength, it is possible to use Huygen's principle to calculate the radiated field. Then, the electric field of the test board can be expressed as [2],

$$E_r \cong E_q \cong 0 \quad (8)$$

$$E_f \cong j \frac{2E_o h}{\mathbf{P} r} e^{-jk_o r} \sin[(k_o W/2) \cos \mathbf{q}] \cos\left(\frac{k_o L}{2} \sin \mathbf{q} \sin \mathbf{f}\right) \frac{\sin \mathbf{q}}{\cos \mathbf{q}} \quad (9)$$

where  $E_o$  is electric field strength at the edge of the patch. From these expressions, the maximum radiated field occurs when  $\mathbf{q} = \pi/2$  and  $\mathbf{f} = 0$ . Using Equation (7), the expression for the maximum radiated field for the TM10 mode can be simplified to,

$$E_{TM10, \max} \cong \frac{k_o V_o}{\mathbf{P} r} (W) \quad (10)$$

where,  $V_o$  is voltage between power and ground planes (i.e.  $V_o = E_o h$ ).

For the TM01 mode, a similar expression may be obtained by observing the geometric symmetry with the TM10 mode.

$$E_{TM01, \max} \cong \frac{k_o V_o}{\mathbf{P} r} (L) \quad (11)$$

The relation between the feed voltage and the voltage across the edges of the board can be found using image theory as shown in Figure 3.

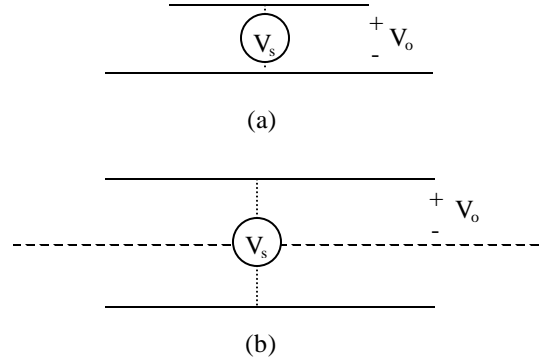

Figure 3. The voltages across the edges of (a) 20-H rule board and (b) normal board.

Using Equations (10) and (11), the ratios of the maximum electric fields from the 20-H rule board and the normal board are given as

$$\frac{E_{\max, 20H}}{E_{\max, normal}} \cong \frac{V_s W_{20H}}{\left(\frac{V_s}{2}\right) W_{normal}} \cong 1.52 \text{ for TM10 mode}$$

$$\frac{E_{\max, 20H}}{E_{\max, normal}} \cong \frac{V_s L_{20H}}{\left(\frac{V_s}{2}\right) L_{normal}} \cong 1.66 \text{ for TM01 mode}$$

These values correspond to 3.6 dB and 4.4 dB, respectively. In other words, based on this simple analysis, we would expect a 9" x 7" board implementing the 20-H rule to radiate at least 3.6 dB more than a normal board at resonant frequencies corresponding to the TM10 and TM01 modes. For larger or thinner boards, we would expect the difference in the two boards to approach 6 dB (a factor of 2 in maximum field strength).

### Total Radiated Power

Although the maximum field strength nearly doubles, the total power radiated does not quadruple because the 20-H rule board tends to focus power in one direction. Using the expression for the far zone electric field, the total radiated power is obtained by integrating the radiated power per unit area over the half-space (area above the ground plane) for the 20-H rule board.

$$\begin{aligned}
P_{rad} &= \int_S \left( \frac{|E|^2}{2h_o} \right) ds \\
&= \frac{V_o^2}{4\pi h_o} \int_0^p \int_0^p \tan^2 \mathbf{q} \cos \mathbf{f} \sin^2 \left( \frac{k_o W}{2} \cos \mathbf{q} \right) \cos^2 \left( \frac{k_o L}{2} \sin \mathbf{q} \cos \mathbf{f} \right) d\mathbf{q} d\mathbf{f}
\end{aligned} \tag{14}$$

The whole space needs to be integrated for the normal board. The ratio of radiated power from the 20-H rule board to that from the normal board is

$$\frac{P_{rad,20H}}{P_{rad,normal}} \cong \begin{cases} 1.8, \text{ for TM10 mode} \\ 1.5, \text{ for TM01 mode} \end{cases} \tag{15}$$

This corresponds to an increase in average radiated power of about 2.6 dB for the TM10 mode or 1.5 dB for the TM01 mode. A numerical modeling code, EMAP5, was used to model the radiated emissions from the two test configurations. Figure 4 shows the total radiated power calculated for each test board as a function of frequency. The resonant frequencies agree well with the calculated values in Table 1 and the TM01 and TM10 resonances are apparent in the plots. Although EMAP5 is a frequency-domain code, it is possible to determine the amplitude of the radiated power at resonance by evaluating several frequency points near resonance. The EMAP5 results confirm the conclusions based on the simple model in the previous section. The radiated power near resonance from the board implementing the 20-H rule is approximately 2-3 dB higher than the power radiated by the normal board.

### MEASUREMENTS

The radiated fields from the 9" x 7" test boards were measured in an anechoic chamber. The test setup is illustrated in Figure 5. An EMCO BiConiLog 3124 antenna, a Rohde & Schwarz FSEB30 spectrum analyzer and an HP8563E signal generator were used to measure the radiated fields from the test boards. Figure 6 shows the measured radiated field in a direction normal to the patch where  $\mathbf{q} = \pi/2$  and  $\mathbf{f} = 0$  (i.e. directly off the front face). From the measured results, it can be seen that the resonant frequencies of the test boards agree well with those listed in Table 1. There are peaks in the measured results corresponding to TM0x and TMx0 mode resonances.

With the long dimension of the board oriented vertically and the antenna oriented vertically, received emissions due to the TM10 mode are maximized. According to Equations (12) and (13), the difference between the peaks at the TM10 mode resonance for the normal board and the 20-H rule board should be 3.6 dB. However, the peaks in the measured result were observed to differ by approximately 7 dB.

With the short dimension of the board oriented vertically and the antenna oriented vertically, received emissions due to the TM01 mode are maximized. According to Equations (12) and (13), the difference between the peaks at the TM01 mode

resonance should be 4.4 dB. However, the peaks in the measured result were observed to differ by less than 1 dB.

The poor agreement between the measurement and the simple expressions in Equations (12) and (13) is probably due to the fact that the measurement is much more complex than the model. Comparing the amplitude of two peaks that occur at different frequencies in different measurements is difficult. Frequency-dependent parameters like the antenna factors, room response, and cable and feed geometries can all affect the measurement. Also our model assumes that the 20-H rule board has essentially an infinite ground plane thereby focusing all of its radiated energy in one half-plane. Field pattern measurements of both boards verified that the 20-H rule board radiated much more strongly off the front face than the back face, but radiation off the back face was not entirely negligible.

Though neither the model nor the measurement were ideal representations of a real PCB implementing the 20-H rule, it is evident that 20-H rule DOES NOT decrease radiated emissions from a board. On the contrary, both the analytic and measured results indicated that boards implementing the 20-H rule exhibit slightly higher emissions at resonant frequencies.

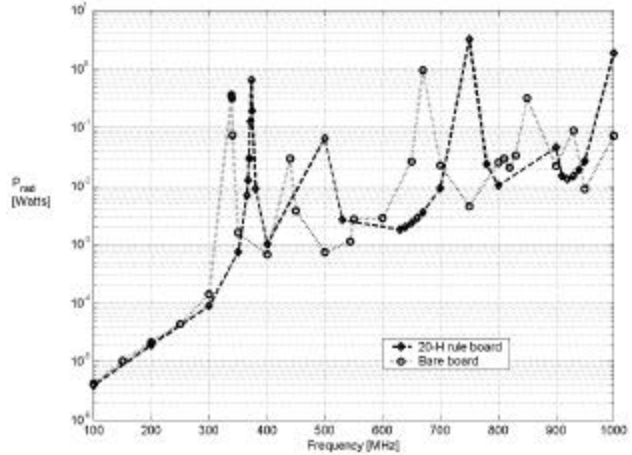

Fig. 4. Radiated power calculated using EMAP5

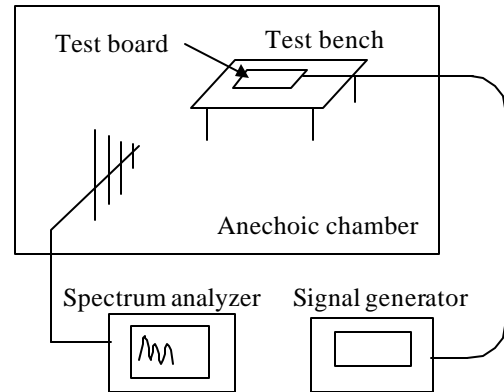

Fig. 5. Setup for measuring the radiated fields.

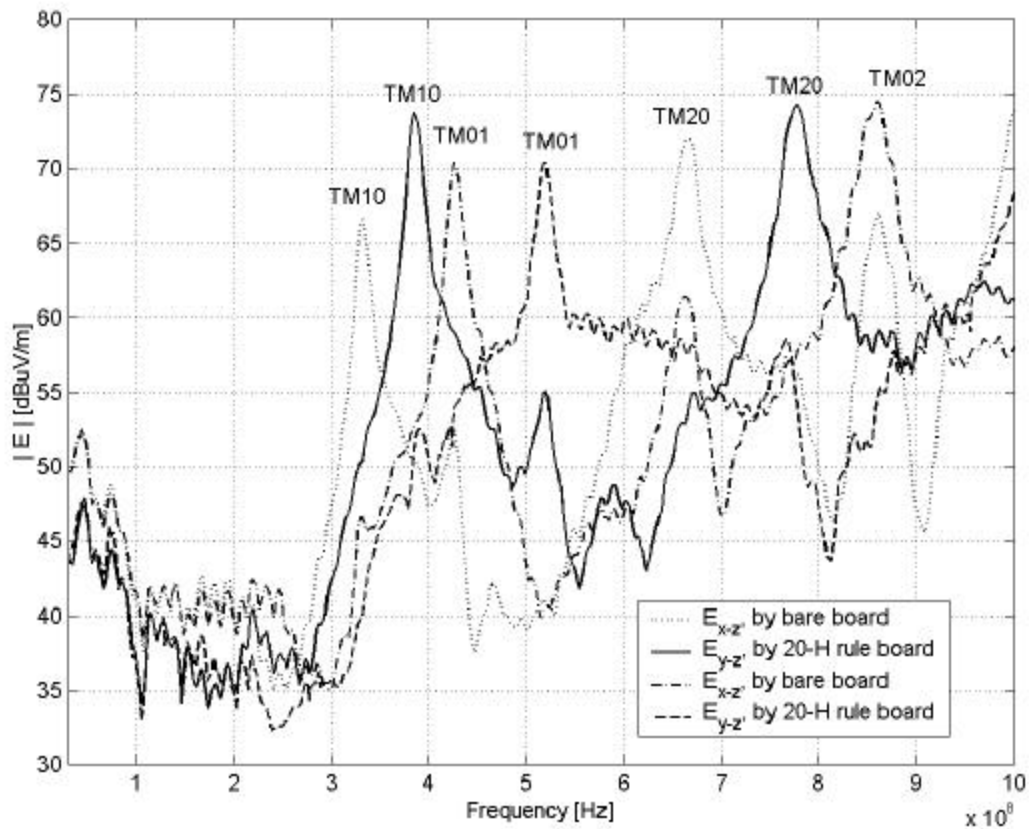

Figure 6. Measured electric field intensity in the direction of normal to plane

## CONCLUSIONS

Two test boards were built and measured to investigate the effect of the 20-H rule on radiated emissions. Analytical, numerical and empirical approaches were used to investigate the behavior of these boards. The results of this study indicate that radiated emissions directly from boards implementing the 20-H rule are actually slightly higher than the emissions from boards with a traditional design. However, the increase is not large and would only be significant in cases where power bus noise radiated directly from the power bus structure was one of the dominant noise sources in a system.

There is no doubt that implementation of a 20-H rule can help to contain the electric field near the edge of the board. This can be useful in situations where it is desirable to avoid coupling to cables, enclosures or other boards located near a board edge.

Like most design guidelines, the 20-H rule can be helpful to those who understand its origin and purpose. However, it can create more problems than it solves when misapplied.

## REFERENCES

- [1] Mark I. Montrose, *Printed Circuit Board Design Techniques for EMC Compliance*, IEEE Press, pp.26-28, 1996.
- [2] Constantine A. Balanis, *Antenna Theory: Analysis and Design*, John Wiley & Sons, 1997, Chapter 14.
- [3] si-list archives, <http://www.qsl.net/wb6tpu/si-list/>