

# Effects of Open Stubs Associated with Plated Through-Hole Vias in Backpanel Designs

Shaowei Deng, Jingkun Mao, Todd H. Hubing,  
James L. Drewniak  
Electrical and Computer Engineering Dept.  
University of Missouri - Rolla  
Rolla, MO, USA  
[sd79c@umr.edu](mailto:sd79c@umr.edu)

Jun Fan, James L. Knighten, Norman W. Smith,  
Ray Alexander  
NCR Corporation,  
17095 Via del Campo  
San Diego, CA 92127  
[jun.fan@ncr.com](mailto:jun.fan@ncr.com)

Chen Wang  
NVIDIA Corporation,  
2701 San Tomas Expressway  
Santa Clara, CA 95050  
[ChenWang@nvidia.com](mailto:ChenWang@nvidia.com)

## Abstract

Plated through-hole (PTH) vias are commonly used in printed circuit boards. They usually leave open stubs if the signal(s) does not transition the entire depth of the board. These open stubs can have a negative impact on signal transmission. This summary reports the investigation of the impact of the open via stubs in a typical backpanel design.

## Keywords

FEM; via; open stub; equivalent circuit; differential transmission line; eye diagram

## I. THE BASIC APPROACH

Plated through-hole (PTH) vias are commonly used in printed circuit boards, even thick boards, such as backpanels, because of the ease of manufacturing, layout, and cost. A potential problem with the use of PTH vias in a backpanel results from the electrical effects of the unused lengths of vias in a signal path. The unused portion of a PTH via can behave as a transmission line open stub in parallel with the signal transmission path. At frequencies that are sufficiently high, this via open stub may load the signal transmission line in an undesirable manner. Since backpanels are typically thicker than other printed circuit boards, the effects of via stubs may be more acute on backpanels than with other types of boards. Typically, backpanels have vias even when the signal transmission is confined to a single layer. For instance, a signal transmitted through a backpanel often originates on a daughter card, goes into the backpanel through a mated pair of connector pins, and continues to another daughter card in reverse sequence. PTH vias are used to connect the connector pins to board traces and are present even when the signal on the backpanel is confined to a single layer.

An approach to model the behavior of vias based on transmission-line models was recently developed [1]. The typical structures in backpanels include both signal traces and vias. We know that signal traces can be modeled

effectively as transmission lines. This work uses transmission-line models for vias as well as traces.

The transmission-line models require that the cross-sectional field distribution be invariant along the axial direction. This assumption is valid for many PCB via structures. Therefore, differential vias can be treated as a multi-conductor transmission line immersed in the PCB dielectric substrate in a manner that is perpendicular to the PCB copper layers. There are discontinuities where pads are attached to via bodies, or vias cross through a reference plane with anti-pads, or dielectric property changes, as illustrated in Fig. 1. In this particular study, we assume that dielectric materials are the same for all the layers, which is typical in FR-4 backpanels. We also assume that the capacitive coupling between via bodies and reference planes is relatively negligible, compared to that between the pads and reference planes. Therefore, the only discontinuity that needs to be accounted for is the via pad.

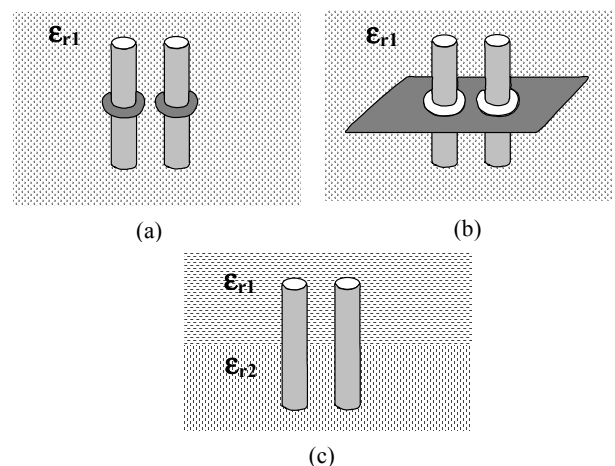

Figure 1. Typical discontinuities, (a) via pads; (b) plane crossing; (c) dielectric interface.

This approach adds lumped capacitance elements to account for the effects of via pads, and the values of these capacitance elements are obtained from quasi-static analysis of the detailed structures including via pads, anti-pads, and reference planes

For example, as shown in Fig. 2, a PTH signal via transits signal from Line 1 to Line 2, while a ground via is placed nearby for signal return. The signal via has pads on the top and bottom outer layers, as well as the interior layer where Line 2 is placed. The ground via is connected to the two ground planes. The equivalent circuit for this geometry, based on the previously described approach, can be developed as shown in Fig. 3.

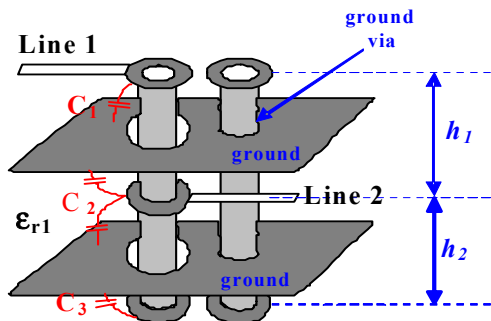

Figure 2. Example geometry: a single-ended case.

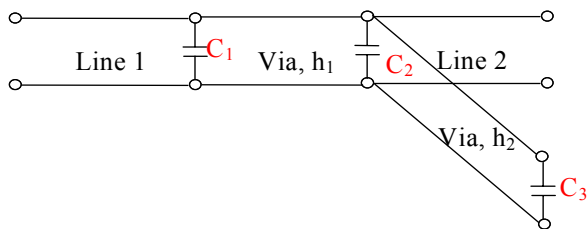

Figure 3. An equivalent circuit for the geometry shown in Fig. 2.

An example of a differential signaling case is shown in Fig. 4, where two PTH signal vias transit differential signal from Line 1 to Line 2. The equivalent circuit for this differential geometry can be developed as shown in Fig. 5.

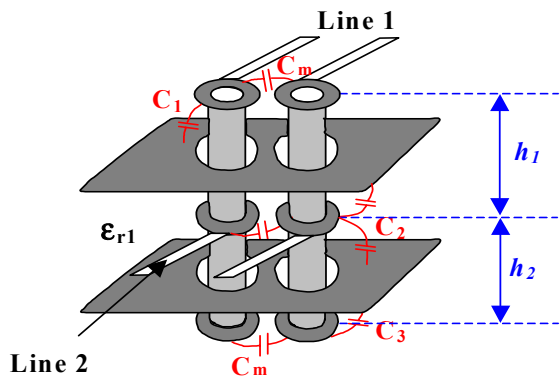

Figure 4. Example geometry: a differential case.

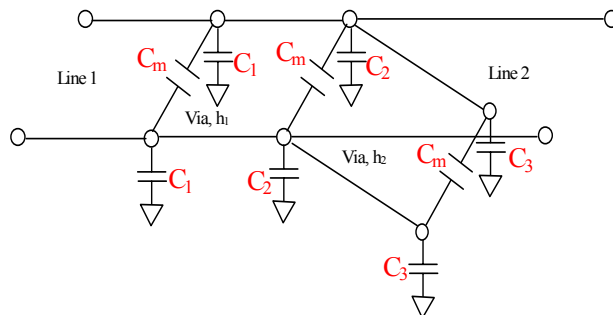

Figure 5. An equivalent circuit for the geometry shown in Fig. 4.

## II. APPROACH VALIDATION

To validate the proposed approach, a signal-ended geometry similar to that shown in Fig. 2 is modeled [2]. It includes a 30.5-cm (12-inch) long single-ended trace, a PTH signal via in the center of the trace, and two PTH ground vias, as shown in Fig. 6. The trace is routed on layer 3 in the stackup shown in Fig. 7, which is a typical 22-layer backpanel, with 10 inner signal layers. In this design, the worst case of using PTH vias is when the signal trace is routed on signal layer 1, which is layer 3 in the board stackup. Then the signal PTH via leaves an open stub that extends from layer 3 all the way down to layer 22, a length of approximately 5.56 mm (219 mils). This open stub has no intended electrical function for signal transmission, but its electrical behavior can cause adverse effects when the data rate is sufficiently high.

The width of the trace is set to 0.32 mm (12.56 mils) so that the characteristic impedance of the trace is 50 ohms. The via diameter is 0.58 mm (23 mils), and the anti-pad diameter is 1.22 mm (48 mils). The pad diameter used in the modeling is 0.76 mm (30 mils). The center-to-center distance between the signal via and each ground via is 1.85 mm. All dielectric layers are assumed to be FR-4 with a dielectric constant of 4.0, and loss tangent of 0.02. For the signal via, it is assumed that there are pads only on the top and bottom layers, as well as on layer 3 where the trace and the via are connected.  $S_{21}$  of the single-ended trace is examined when the trace is matched at both ends.

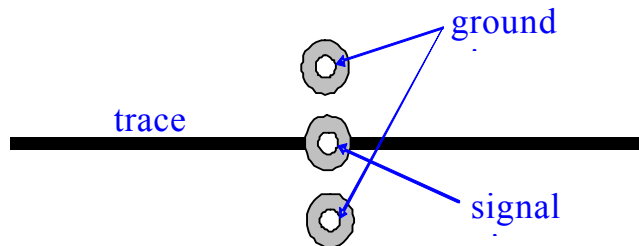

Figure 6. Top view of the example geometry.

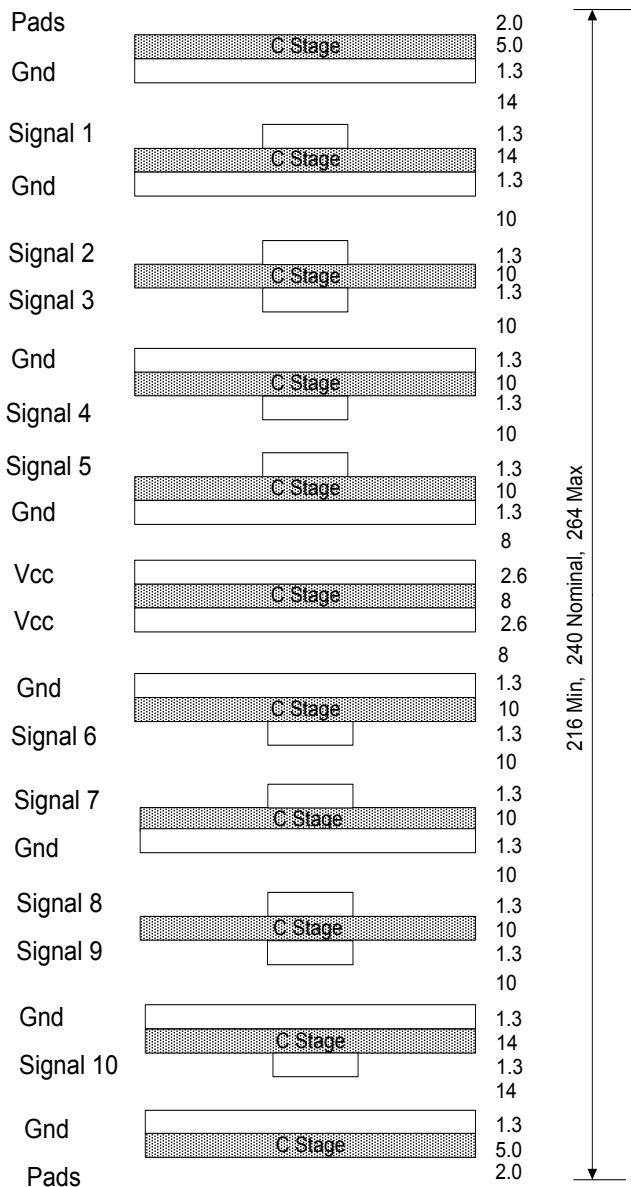

Figure 7. A typical layer stackup for backpanels.

The equivalent circuit for this geometry is shown in Fig. 8. Via stub  $h_1$  is the portion of the via from layer 3 to layer 1 and via stub  $h_2$  is the portion of the via from layer 3 down to layer 22.  $C_1/C_3$  represents the capacitance between the top/bottom signal via pad and the ground structure, comprised of two ground via pads on the same layer and the adjacent ground plane as shown in Fig. 9(a);  $C_2$  represents the capacitance between the signal pad on the signal layer and the adjacent ground planes as shown in Fig. 9(b). The values of the capacitances  $C_1$ ,  $C_2$  and  $C_3$  are calculated using ANSYS ( $C_1 = 0.07$  pF,  $C_2 = 0.15$  pF and  $C_3 = 0.07$  pF). The equivalent circuit is simulated with HSPICE to study  $S_{21}$  of the two-port system. Dielectric and skin-effect losses are included.

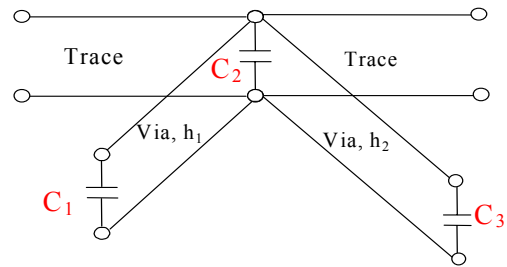

Figure 8. An equivalent circuit for the validation geometry.

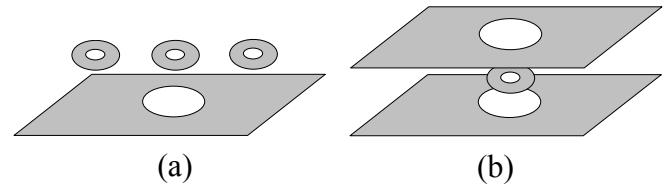

Figure 9. Calculating capacitances: (a)  $C_1$  and  $C_3$ ; (b)  $C_2$ .

An FEM simulation for the same geometry was conducted using Ansoft HFSS. Dielectric and skin-effect losses were included in the HFSS and transmission line models. Absorbing boundary conditions were applied to the ground planes so that they appear to be infinitely large in the modeling. The comparison of the modeled  $|S_{21}|$  in the frequency range 0 - 12 GHz using the HFSS, the transmission-line approach and Cohen's measurement result for a similar backpanel PTH via structure in [2] is shown in Fig. 10. Instead of the smooth behavior exhibited by a typical board trace, the modeled  $|S_{21}|$  shows a resonance due to the open stub. This resonance is undesirable for signal transmission because it causes increased losses at frequencies near it. The two modeling results agree approximately, with a slight discrepancy (0.4 GHz) near the resonant frequency, which may partly result from neglecting the capacitive coupling between the via body and the ground planes.

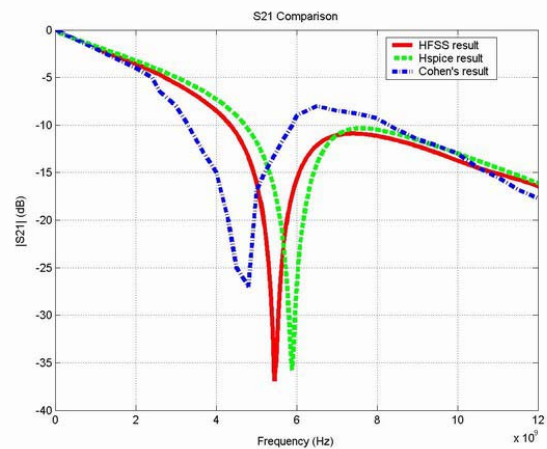

Figure 10. Comparison of HFSS, transmission-line approach and Cohen's measurement result in [2] for a single-ended case.

### III. DIFFERENTIAL SIGNALING

The effects of the open stubs for differential signals that are commonly used in high data rate serial transmissions can also be investigated using the transmission-line approach. A typical signal transmission path from a daughter card to a backpanel, and then to another daughter card, is of interest. The daughter cards are connected to the backpanel through connectors. Connector PTH vias run from the top surface to the bottom surface of the board. The differential signal trace pair is routed on signal layer 1. The portion of the vias from signal layer 1 to the bottom surface is actually not used (an open stub). This open stub is in parallel with the signal transmission path. When the length of the open stub is approximately one-quarter wavelength, the signal is loaded with a short. In this circumstance, a large amount of energy will be reflected by the open stub unintentionally. A simplified geometry is shown in Fig. 11, where the vias at the both ends of the trace represent the vias needed for the backpanel connectors.

The line width for the differential trace is 0.1777 mm (6.996 mils), and trace edge-to-edge spacing is 0.2286 mm (9 mils). The differential impedance is 102 Ohms for the stackup shown in Fig. 7. All dielectrics are assumed to be FR-4 with a dielectric constant of 4.0 and loss tangent of 0.02. The via diameter is 0.58 mm (23 mils). The anti-pad diameter is 1.22 mm (48 mils) and the pad diameter used in the modeling is 0.76 mm (30 mils).

As discussed in the transmission line approach, the via open stubs are treated as transmission line segments, while the differential pair is modeled using the HSPICE W-element. The effects of the pads and anti-pads are modeled by equivalent capacitances.

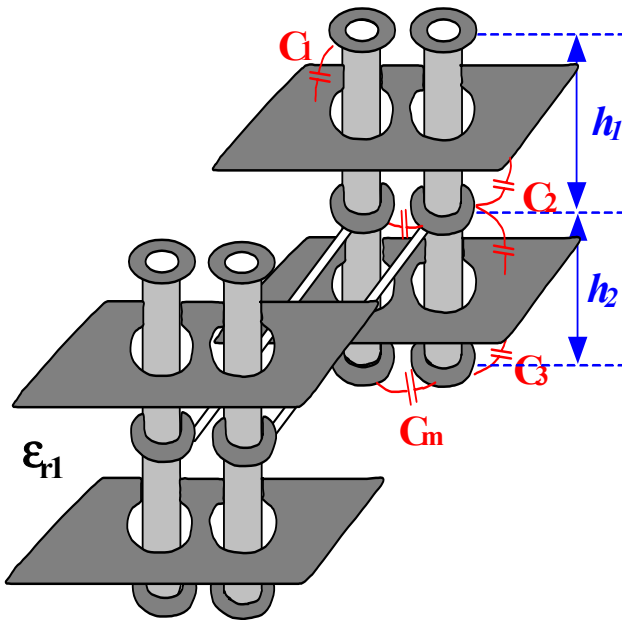

Figure 11. Differential signaling in backpanel with PTH vias.

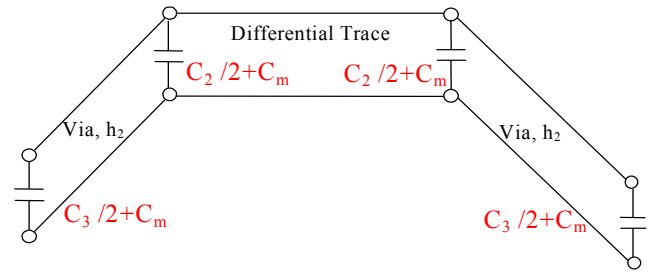

Figure 12. Equivalent lumped circuit for the differential signaling.

The equivalent circuit model for the differential signaling structure illustrated in Fig. 11 is shown in Fig. 12.  $C_2$  represents the capacitance between one signal via pad and the adjacent two ground planes and  $C_3$  represents the capacitance between one bottom via pad and the adjacent ground plane.  $C_m$  represents the mutual capacitance between the two signal via pads. Thus the total capacitance between the signal via pads is equal to  $C_2/2 + C_m$  (0.084 pF) and  $C_3/2 + C_m$  (0.038 pF) correspondingly. The mixed-mode s-parameter  $S_{dd21}$  is modeled, which describes the loss of a pure differential signal transmitted along the signal path [3]. A 1.27-cm (0.5-inch) long differential trace is studied, to focus on the effects of the via stubs by minimizing the effects of the trace itself. The modeled  $|S_{dd21}|$  results with 5.56-mm (219-mil) long PTH vias at the ends are shown in Fig. 13, compared with the results when only the traces (no via stubs) are under consideration. As shown in Fig. 13, the PTH vias introduce the first notch at approximately 6 GHz, and the second at approximately 18 GHz. The quality factor  $Q$  of the first resonance at 6 GHz is estimated to be approximately 7.5 from Fig. 13 [4]. Furthermore, the trace-only case (no vias) results in lower transmission loss over the entire frequency range up to 24 GHz. The notch is primarily due to the quarter-wavelength resonance of the open stubs, while also affected by the capacitive load presented by the pads and anti-pads.

In the time domain, an eye diagram is commonly used to evaluate the quality of digital data transmission. To study the effects of the via open stubs to high-speed signals in the time domain, eye diagrams are generated using the modeled s-parameters [5]. Fig. 14 shows the eye diagram without stubs. The bit rate for the input data stream is 12 Gb/s, with a 10%-90% rise time of 20 ps. The bit pattern is a repetitive twenty-bit pattern consisting of a K28.5 comma followed by an inverse comma, or 3EB05H (00111110101010000101). This bit pattern waveform is shown in Fig. 15, ignoring rise/fall times. Fig. 16 shows the eye diagram with 5.56-mm long stubs. The effects of the via open stubs for this particular data stream is very severe (Fig. 16), and the eye is largely closed with the stubs (a simple eye height of approximately 0.1 V). Notice that the eye without the stubs (Fig. 14) is fully opened, with an eye height of approximately 0.45 V. This data rate was intentionally chosen so that the fundamental frequency is 6 GHz, which is close to the first notch frequency of the via stub so that the effect on signal transmission was maximized.

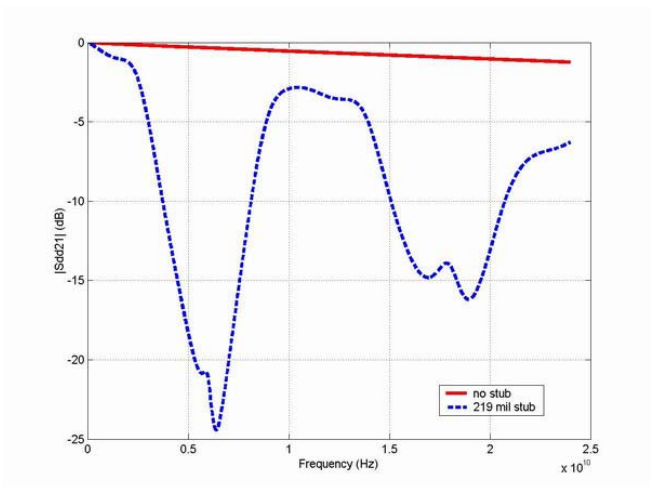

Figure 13. Frequency domain  $|S_{dd21}|$  comparison of the effects of the open via stubs seen in Fig. 11 vs. a transmission line without via stubs.

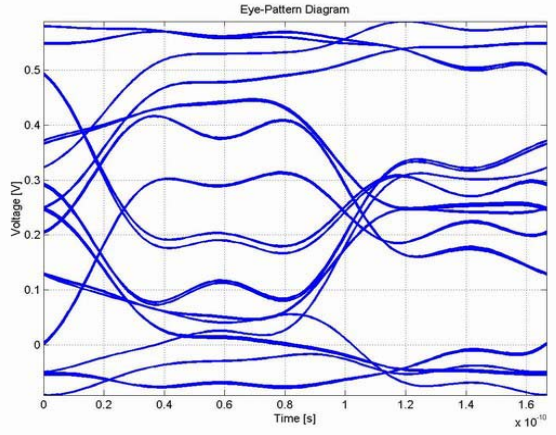

Figure 16. Time domain eye diagram for the case with 219 mil long via stubs for the bit pattern used in Fig. 14.

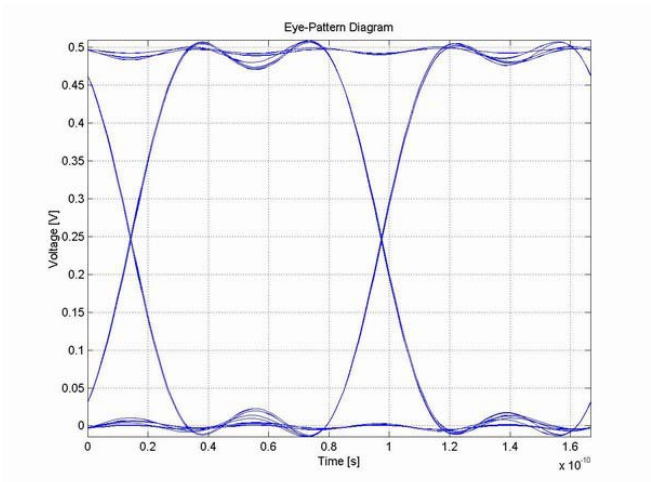

Figure 14. Time domain eye diagram of the repetitive bit pattern 3EB05H at 12 Gb/s and 20 ps risetime when there are no via stubs.

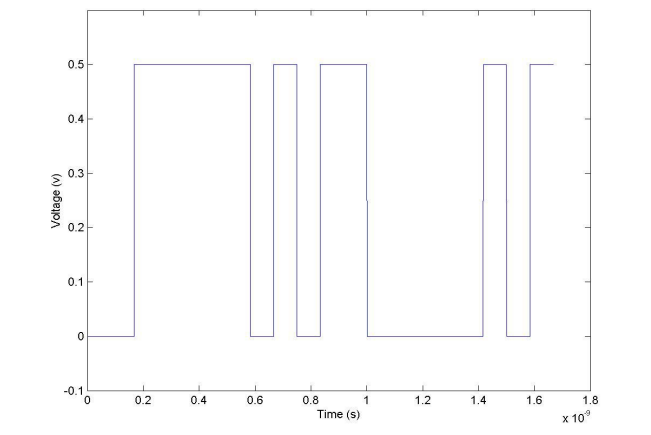

Figure 15. Wave form of the bit pattern used to generate the eye diagram.

The effects of the stub length were studied by varying the length of the open stubs and simultaneously monitoring the  $|S_{dd21}|$  results. As shown in Fig. 17, the lowest notch frequency is shifted higher when the via stub length is decreased; indicating that only the higher-data-rate signals would then be significantly affected. In this study, the geometry shown in Fig. 11 is used with a trace length equal to 30.5 cm, and the capacitive coupling between the pads and ground planes is neglected. Fig. 17 shows modeled results for six different open stub lengths and demonstrates that the notch frequency depends on the length of the open stub. In addition, when comparing Fig. 17 with the “no stub” results in Fig. 13, it is clear that at specific frequencies the overall differential signal transmission strength  $|S_{dd21}|$  for the 30.5-cm trace is less than for the 1.27-cm trace, reflecting higher losses in the longer trace. Also, the slope of the decrease in  $|S_{dd21}|$  is more rapid with the increase in frequency, compared to that for the 1.27-cm trace shown in Fig. 13. This difference in slope is expected if the per unit length loss remains the same for both traces.

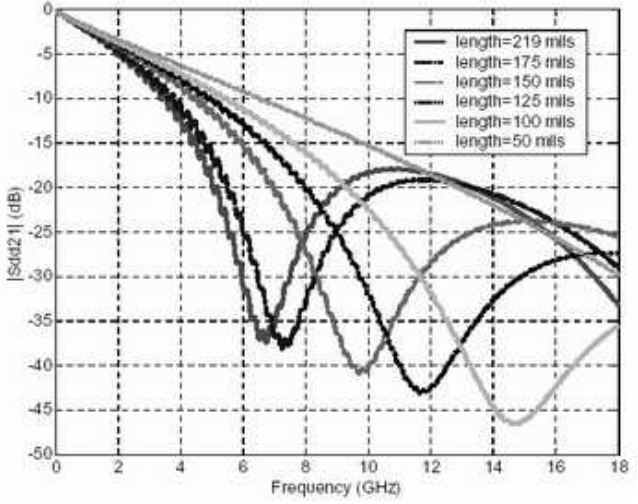

Figure 17. Modeled  $|S_{dd21}|$  results when varying the length of the open stubs.

#### IV. CONCLUSION

A transmission-line approach is used to model the effects of the via open-stubs in typical backpanel signal transmissions. This approach uses transmission-line segments to model vias, with the effects of pads, anti-pads, and ground planes being accounted for by lumped capacitances. Modeled scattering parameters compare favorably with those from a full-wave FEM method, demonstrating that modeling PTH vias in backpanels as transmission line segments is reasonably good for engineering studies. Differential signaling with the PTH vias is investigated in both the frequency and time domains. The resonance due to the via open stubs can seriously affect the transmission of high speed digital data. In the case examined, the eye height was reduced by 80% or more.

#### REFERENCES

- [1] Chen Wang, James L. Drewniak, Jun Fan, James L. Knighten, Norman W. Smith, and Ray Alexander, "Transmission line modeling of vias in differential signals," The IEEE International Symposium on Electromagnetic Compatibility, Minneapolis, MN, August 19-23, 2002, vol. 1, pp. 249-252.
- [2] Tom Cohen, "Practical guidelines for the implementation of back drilling plated through hole vias in multi-gigabit board applications," DesignCon, 2003.
- [3] David E. Bockelman and William R. Eisenstadt, "Combined differential and common-mode scattering parameters: theory and simulation," IEEE Transactions on microwave theory and techniques, Vol. 43, No. 7, July 1995.
- [4] David M. Pozar, "Microwave Engineering", Second Edition, pp. 300 - 312, Johns Wiley & Sons, Inc, 1998.
- [5] G. Antonini, J. L. Drewniak, A. Orlandi, V. Ricchiuti, "Eye pattern evaluation in high-speed digital systems analysis by using MTL modeling" IEEE Transactions on microwave theory and techniques, Vol. 50, No. 7, July 2002.