

Automotive Component Measurements for Determining Vehicle-Level Radiated Emissions

Todd Hubing

Michelin Professor of Vehicular Electronics
Clemson University



Automobiles are Complex Electronic Systems

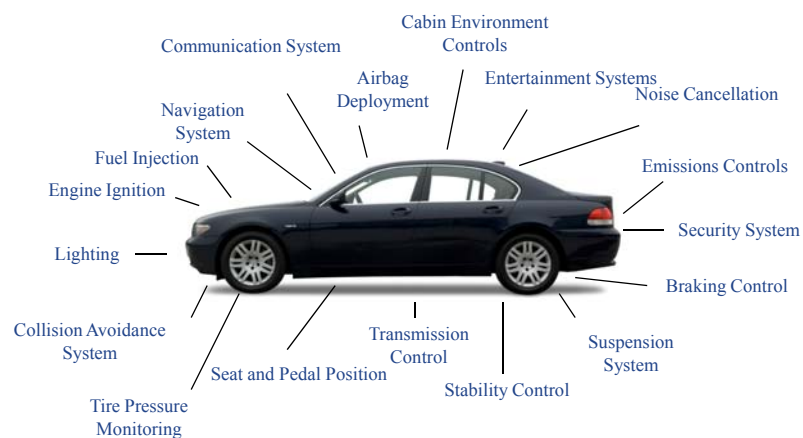

EMC Europe 2008

2

Can we predict system-level performance from component-level information?



Can we predict system-level performance from component-level information?

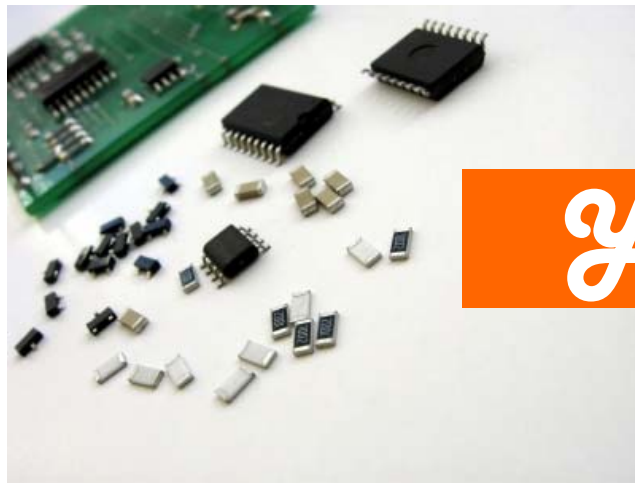

Yes!

CISPR-25 Component-Level EMC

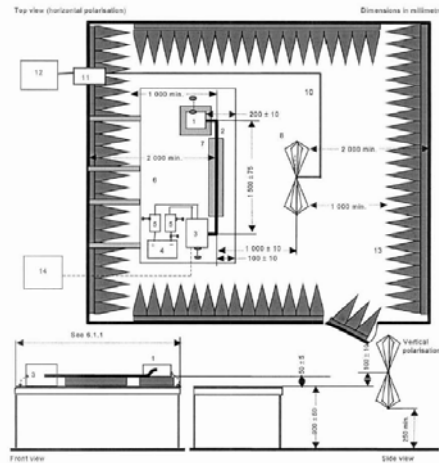

CISPR-25
Measurements
do not provide
appropriate
information for
system-level
simulation!

**We need to characterize automotive
components the way we characterize circuit
board components!**

Old Approach: Put the components in a “typical” system and measurement the system performance.

Better Approach: Fully characterize the components themselves, then model system behavior.

Case in Point: Integrated Circuit EMC Measurement Methods

- ❑ IEC 61967-1 General conditions and definitions
- ❑ IEC 61967-2 Measurement of radiated emissions
TEM cell method
- ❑ IEC 61967-3 Measurement of radiated emissions
surface scan method
- ❑ IEC 61967-4 Measurement of electromagnetic emissions
1 Ω /150 Ω direct coupling
- ❑ IEC 61967-5 Measurement of electromagnetic emissions
workbench Faraday cage method
- ❑ IEC 61967-6 Measurement of electromagnetic emissions
magnetic probe method

Integrated Circuit EMC Measurement Methods

- ❑ IEC 61967-1 General conditions and definitions
- ❑ IEC 61967-2 Measurement of ~~radiated~~ emissions
TEM cell method *field-coupled*
- ❑ IEC 61967-3 Measurement of ~~radiated~~ emissions
surface scan method *near fields*
- ❑ IEC 61967-4 Measurement of ~~electromagnetic~~ emissions
1 Ω /150 Ω direct coupling *conducted*
- ❑ IEC 61967-5 Measurement of ~~electromagnetic~~ emissions
workbench Faraday cage method *who knows what*
- ❑ IEC 61967-6 Measurement of ~~electromagnetic~~ emissions
magnetic probe method *who knows what*

Integrated Circuit EMC Measurement Methods

Component measurements should characterize the source in order to build models that can be used at the system level.

Otherwise, they are mostly useless!

Integrated Circuit EMC Measurement Methods

Measurements must be:

- Meaningful
- Repeatable
- Targeted

Integrated Circuit EMC Measurement Methods

Standards SAE J1752/3 and IEC 61967-

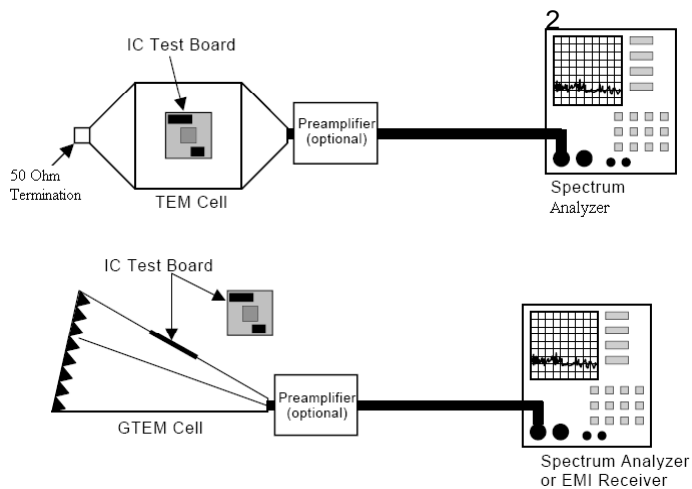

Energy must be coupled from an IC before it can be radiated.

- ❑ Integrated circuits (ICs) are generally the ultimate source of unintentional electromagnetic emissions from electronic devices and systems.
- ❑ However, ICs are too small to radiate significantly themselves.
- ❑ In order to radiate fields strong enough to cause an interference problem, energy must be coupled from the IC package to larger structures that act as antennas such as circuit board planes, heatsinks or cables.

Energy must be coupled from an IC before it can be radiated.

There are only three ways that energy can be coupled from an IC to surrounding structures:

- ❑ Conducted on two or more pins;
- ❑ Electric field coupled;
- ❑ Magnetic field coupled.

Electric Field Coupling to the Septum of a Mini-TEM Cell

Electric field coupling can be represented with a mutual capacitance, C_{TEM} . The voltage coupled to either end of the TEM cell will be identical.

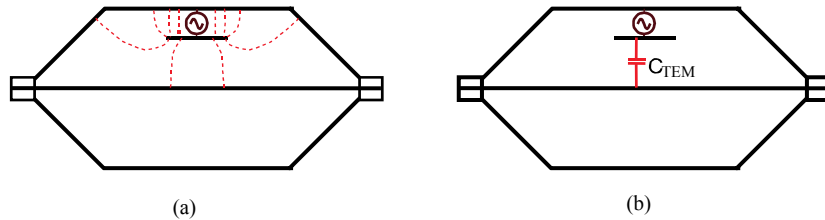

Magnetic Field Coupling to the Septum of a Mini-TEM Cell

Magnetic field coupling can be represented with a mutual inductance, M_{TEM} . Voltage appears across both terminations with opposite phase.

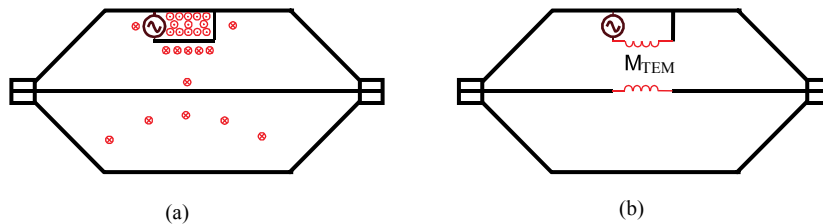

Separating Coupling Mechanisms Using a Hybrid Coupler

- A hybrid can be used to differentiate electric and magnetic field coupling.
- The A-B output indicates the amount of magnetic field coupling.
- The A+B output indicates the amount of electric field coupling.

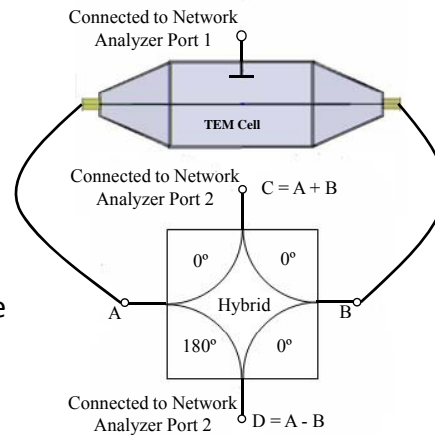

Electric Field Coupling

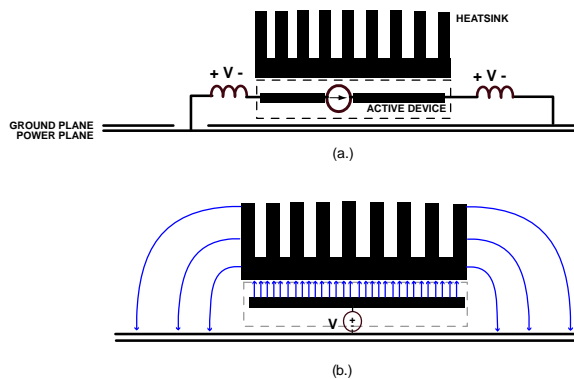

Voltage-Driven Radiation Mechanism

If we know C_{trace} and V_{DM} , we can calculate maximum possible radiated emissions due to electric field coupling!

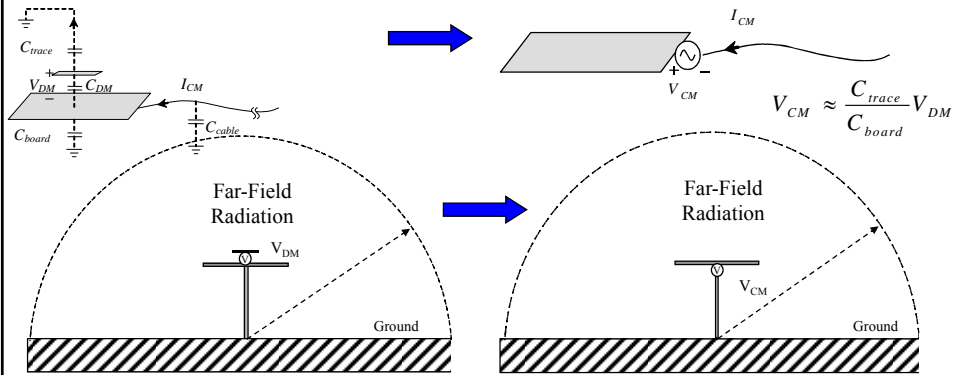

Correlating C_{trace} to C_{TEM}

A TEM cell measurement gives us the product of C_{trace} and V_{DM} , which is sufficient to calculate maximum possible radiated emissions due to electric field coupling!

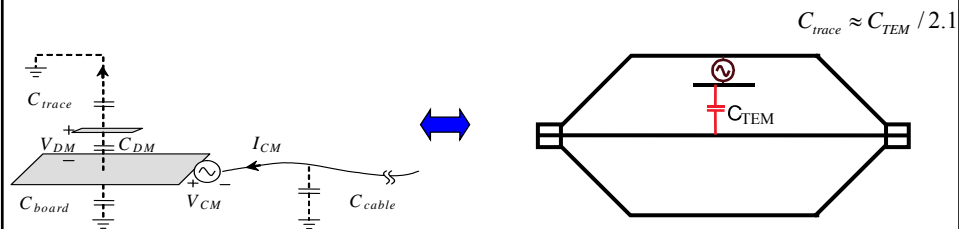

S. Deng, et. al., "Characterizing the Electric-Field Coupling from IC-Heatsink Structures to External Cables using TEM-Cell Measurements," *IEEE Trans. on Electromagnetic Compatibility*, vol. 49, no. 4, Nov. 2007, pp. 785-791.

Calculation of Emissions Based on TEM Cell Measurement

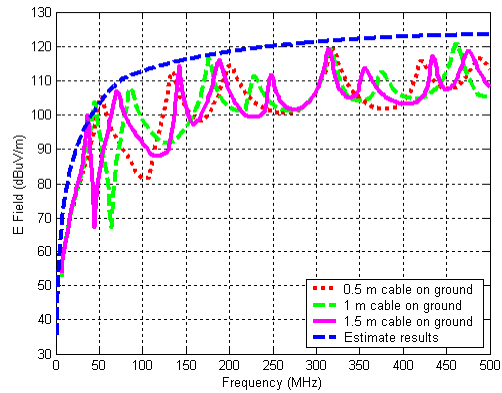
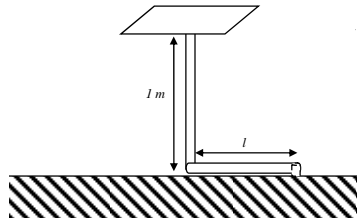

Magnetic Field Emissions

Current-Driven Common-Mode (Magnetic-Field) Coupling

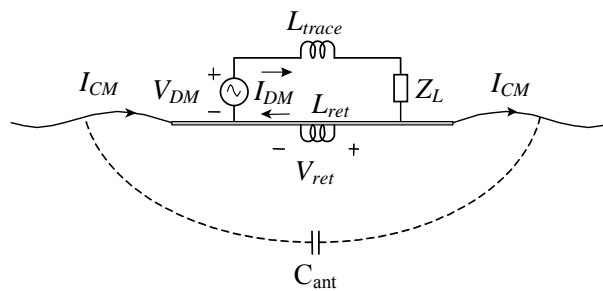

Source can be fully characterized by the current I_{DM} and the mutual inductance (source loop to antenna loop).

Magnetic Field Emissions

A TEM cell measurement gives us the value of V_{CM} , which is sufficient to calculate maximum possible radiated emissions due to magnetic field coupling!

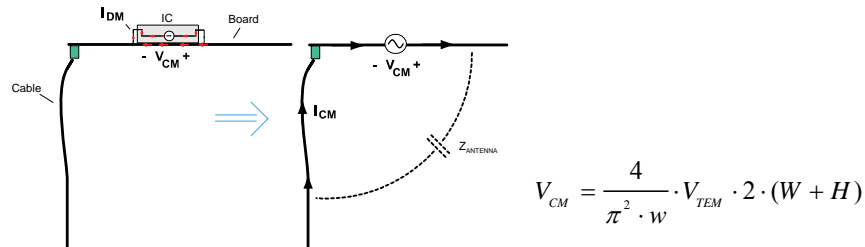

S. Deng, et. al., "Using TEM Cell Measurements to Estimate the Maximum Radiation from PCBs with Attached Cables due to Magnetic Field Coupling," accepted for publication in the *IEEE Transactions on Electromagnetic Compatibility*.

Using TEM Cell Measurement Results

- By connecting both outputs of the TEM cell to a hybrid, it is possible to separate the electric field coupling from the magnetic field coupling.
- Magnetic-Field coupling is fully characterized by the source current and mutual inductance to the radiating structure. These are both determined by the TEM cell measurement.
- Electric-Field coupling is fully characterized by the source voltage and the capacitance of the device being driven to infinity. These can both be determined by the TEM cell measurement.
- Therefore, a TEM cell measurement can be used to extract the parameters required to predict maximum radiated emissions due to coupling from an electrically small source.

Hybrid TEM Cell Electric Field Coupling

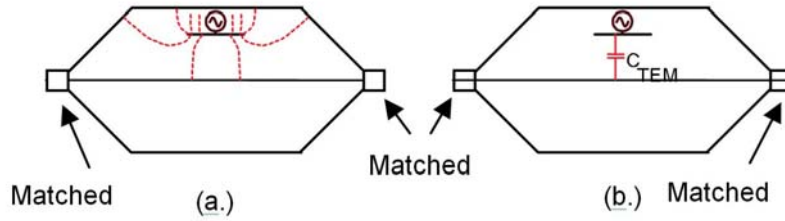

**Electric
Moment**

$$|V_{IC}| \omega C_{TEM} \approx \frac{|V_{measured}|}{25}$$

Hybrid TEM Cell Magnetic Field Coupling

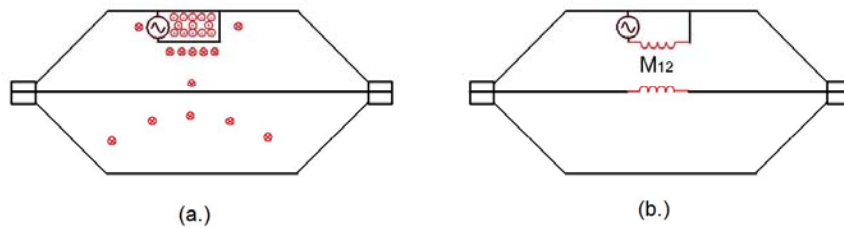

**Magnetic
Moment**

$$|V_{measured}| = |I_{IC}| \omega M_{TEM}$$

Conducted Coupling

Near magnetic field measurements are the best way to map high-frequency currents; but not the best way to quantify them.

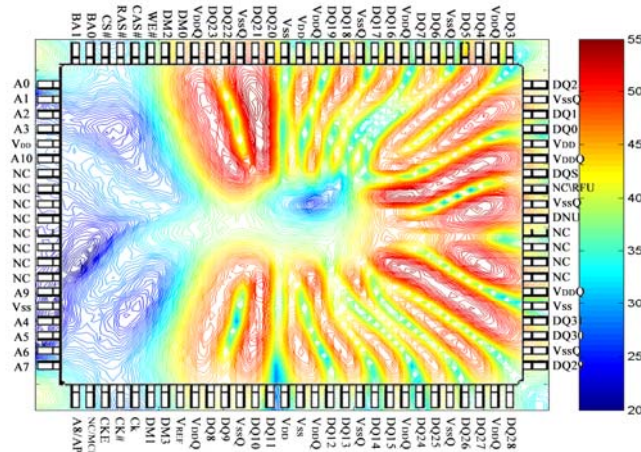

ICEM Models

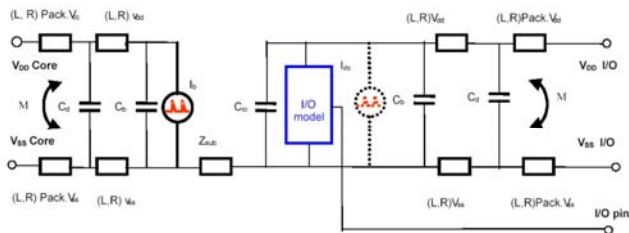

ICEM is a potentially powerful tool for modeling the EMC of ICs in systems.

We'd like to have a simple measurement procedure that would give us ICEM models, the ICEM models are too complex for EMC approval testing of ICs.

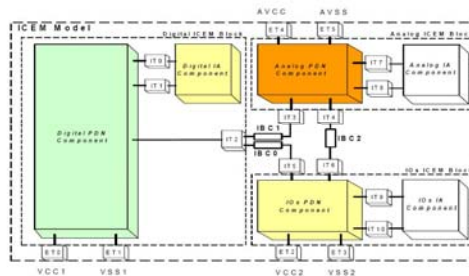

Conducted Coupling

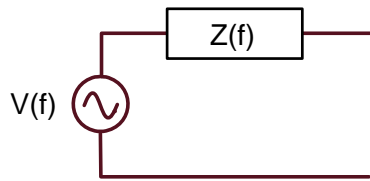

- Need a Thevenin Equivalent source for each terminal pair, including power pins.

- R_{min} is ratio of V_{open} to I_{short_max}
- Reactive elements are not necessary
- Only "logical" ports need to be characterized.

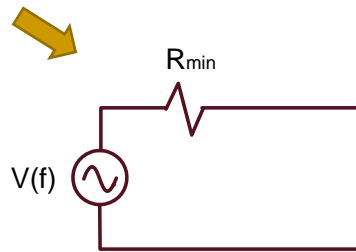

Conducted Coupling

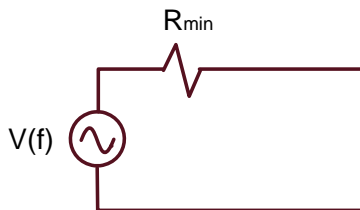

Existing methods for measuring conducted emissions are limited by parasitics, however it is often possible to make meaningful measurements up to GHz frequencies.

- V_{open} is approximately equal to the voltage measured across a 150 W load if connection parasitics are controlled.
- I_{short_max} is approximately equal to the current delivered to a 1 W load if connection parasitics are controlled.
- Internal capacitances can be modeled explicitly if known or implicitly included in the value of $V(f)$

Radiated Emissions

- ❑ Radiated emissions can't be measured in a TEM cell!
- ❑ Radiated emissions can't be measured by an antenna located in the near field of the source.
- ❑ We don't want to know the radiated emissions from a "typical" system, just the emissions directly from the component.
- ❑ Recommendation: Place the component on a raised metal floor in a semi-anechoic environment and put all supporting equipment below the floor (or outside the chamber).

Automotive System Solution

- ❑ Automotive components are often the source of radiated energy, but usually not the "antenna" below several hundred MHz.
- ❑ Automotive components usually couple to the structures that serve as antennas by way of conducted, electric-field, or magnetic-field coupling.
- ❑ The electric and magnetic field coupling from a component can often be quantified by measurements using a TEM Cell and a hybrid coupler.
- ❑ These measurement results can be expressed as electric or magnetic moments that describe a components ability to couple to nearby objects.

Automotive System Solution

- ❑ Radiated emissions can be quantified with a radiated field measurement of the component (must be in the true far field).
- ❑ Common-mode current measurements on the harness are more useful than radiated emissions measurements that include the harness.
- ❑ Conducted emissions can be quantified by high-impedance voltage and low-impedance current measurements at the harness interface.

Can we predict system-level performance from component-level information?



Yes!

Existing EMC test standards can help to identify potential problems with a component before it is installed in a system; but they are not very helpful for predicting system-level behavior.

New EMC test procedures employing hybrid TEM cells, high-impedance voltage and low-impedance current measurements, and true radiated emissions measurements will quantify the important parameters of interest providing component-level information that can be used to predict system-level performance.