

FDTD MODELING OF EM1 ANTENNAS

Motoshi Tanaka^{†*}, Wei Cui[†], Xiao Luo[†], James L. Drewniak[†]
Todd H. Hubing[†], Thomas P. VanDoren[†], and Richard E. DuBroff[†]

[†]University of Missouri-Rolla,
Rolla, MO, USA

[‡]Lucent Technologies, Norcross, GA, USA

*Akita University, Akita, Japan

Abstract: The FDTD (Finite-Difference Time-Domain) method is used for modeling EM1 antenna geometries to anticipate EM1 problems in high-speed digital designs. FDTD is well-suited to modeling large-scale geometries such as cables that might be driven against PCB ground planes as a result of a noise voltage that appears at the connector. Three specific cases are addressed herein including a simple cable driven against a PCB ground, coupling between a high-speed digital and I/O line that drives a cable against the PCB, and the finite impedance of the PCB reference plane that results in an effective noise source that drives the PCB ground against the cable. The FDTD modeling is compared with measurements. Guidelines for coupling to I/O lines, and a keep-out distance around the board periphery for high-speed digital lines can then be developed.

INTRODUCTION

An EM1 problem is typically comprised of a noise source, EM1 antenna, and a parasitic coupling path between the noise source and antenna. A cable attached to a printed circuit board that might be driven by an effective noise source at the connector against the PCB ground or a shielding enclosure is a common EM1 problem. It is helpful to be able to anticipate in design the resonances of such antenna configurations where the EM1 can peak. Also, by knowing the current distribution on the cable, a ferrite sleeve used to mitigate the problem can be placed at the common-mode current maximum for optimal effectiveness. An equivalent circuit model of the EM1 antenna with frequency can be used with noise source and coupling path models at the PCB level to estimate the radiated field strength for EM1 compliance. Finally, by selectively modeling the EM1 antenna geometry with PCB level coupling paths, EM1 design guidelines can be developed.

EM1 antenna modeling for three configurations is detailed herein. Specifically, a simple geometry of a wire driven against a PCB ground plane is considered first. Among the critical issues is determining what must be modeled, and how to model it in order to achieve good agreement with measurements. An experimental procedure for measuring common-mode current on an attached

cable has been developed for this purpose. A second case, that is a common EM1 problem in automotive designs is noise coupling between high-speed digital and I/O lines that drives the cable against the PCB ground. The problem is worked in two steps using transmission-line modeling at the PCB level to calculate the effective noise source at the EM1 antenna terminals, and then using this noise voltage with FDTD to determine the common-mode current on the cable and the radiated EM1. Finally, a PCB level noise source that results from the finite impedance of the PCB reference planes is studied to determine the necessary "keep-out" area on the board periphery for high-speed trace routing.

MODELING OF PCB TYPE EM1 ANTENNAS

An attached cable connected to an I/O line on a PCB can be driven as an unintentional antenna resulting in EM1 [1][2]. The modeling of a simple PCB type EM1 antenna is discussed first. Figure 1 shows the modeling and the geometry of the EM1 antenna under test for a PCB type EM1 antenna. A 20 cm long thin wire, 0.06 cm in diameter, is connected to a 0.085" semi-rigid cable, at the edge of a 15 cm x 20 cm PEC (Perfect Electric Conductor) board, which is comprised of a PCB with two copper planes. The feed point (source) of the EM1 antenna is the point where the extended wire is connected. The semi-rigid cable is extended beyond the PEC board for 2.5 cm, and soldered in the middle of the PEC board. The other end of the cable is connected to an SMA connector.

The FDTD method (Yee's algorithm [3]) was used for modeling the EM1 antenna. The thin wire was modeled with a subcellular algorithm [3]. This approach was also used for give the source a specified radius as well [1]. A cell size of $\delta x = 1.5$ cm, $\delta y = 1.25$ cm and $\delta z = 1.5$ cm was used in the frequency range from 50 MHz to 1 GHz. The dimensions of the EM1 antenna model was 46 x 41 x 46 cells in the $x, y,$ and z dimensions. The time step was $\delta t = 2.0E-11$ s from the Courant stability condition [3],

$$\delta t \leq \frac{1}{c \sqrt{\frac{1}{(\delta x)^2} + \frac{1}{(\delta y)^2} + \frac{1}{(\delta z)^2}}} \quad (1)$$

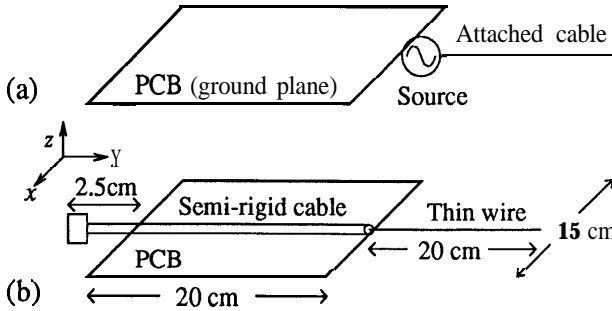

Figure 1: Basic Model of a PCB type EMI antenna. (a) modeling, (b) geometry of the EMI antenna under test.

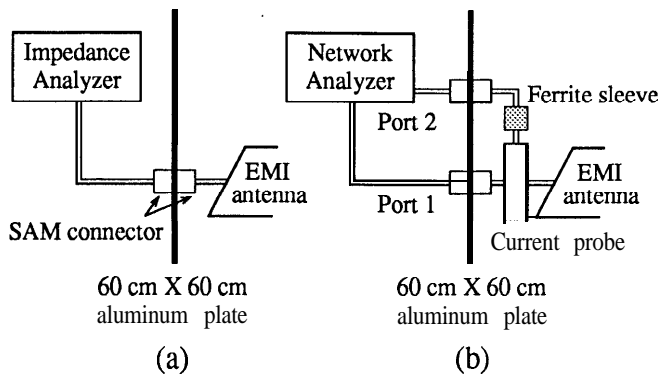

Figure 2: Experimental set-up. (a) input impedance, and (b) $|S_{21}|$ related to the common-mode current.

where c is light speed.

An FDTD code developed in the authors' laboratory was used for numerical calculation. PMLs (Perfectly Matched Layers) are used for the absorbing boundary condition [3]. A sinusoidally modulated Gaussian pulse was used as the source. The voltage and current at the source was calculated to get the input impedance, and, at the same time, the current at the center of semi-rigid cable was calculated to get the common-mode current. The aluminum plate used in the experiments was included in the FDTD modeling.

The input impedance Z_{in} of the EMI antenna was measured using an RF impedance analyzer (HP 4291A) as shown in Fig. 2(a). $|S_{21}|$ with the locations of Port 1 (the voltage source for the signal trace) and Port 2 (current probe on the cable) was measured by using a network analyzer (HP 8753D) as shown in Fig. 2(b), where $|S_{21}|$ is related to the common-mode current on the EMI antenna [1][2]. A current probe (Fischer F-2000) was mounted to the aluminum plate and circled the coaxial cable. A 60 cm x 60 cm aluminum plate was used to isolate the PCB model from the cable dressing leading to a network analyzer or an impedance analyzer.

The relationship between $|S_{21}|$ and the common-mode current is described below. The calibration of the network analyzer and removal of the frequency response of the cur-

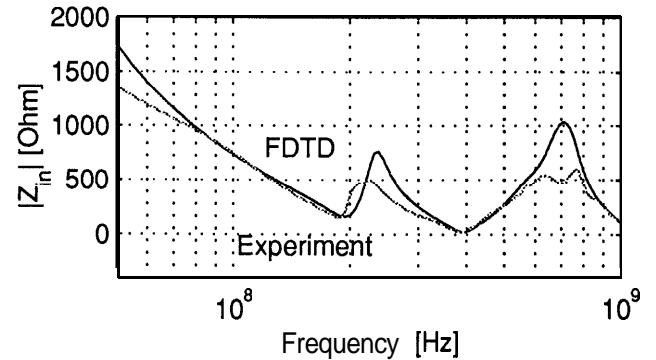

Figure 3: The input impedance $|Z_{in}|$ of the EMI antenna with FDTD modeling and measurement.

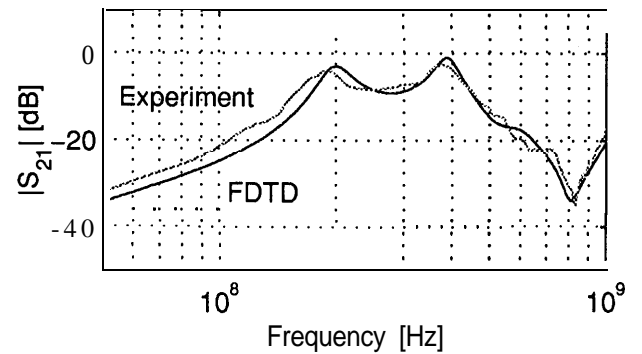

Figure 4: $|S_{21}|$ of the EMI antenna with FDTD modeling and measurement.

rent probe are done by using copper ring which is tightly wrapped around the probe. The current I_{Port1} in the copper ring at low frequencies is given by $I_{Port1} \approx V_{DM}/50$, where V_{DM} is the RF source voltage of the network analyzer, and the source impedance of the network analyzer is 50Ω . The voltage at Port 2 is given by $V_2^- = 50I_{Port2}$, where I_{Port2} is the current sensed by the current probe. The currents in Port 1 and Port 2 are related by the frequency response of the current probe $H_{pr}(f)$, therefore $I_{Port2} = H_{pr}(f)I_{Port1}$. As the source impedance is matched to the characteristic impedance of the cable, the voltage at Port 1 is given by $V_1^+ = V_{DM}/2$. Then $|S_{21}|$ before calibration is given by

$$|S_{21}| = \left| \frac{V_2^-}{V_1^+} \right| = \left| \frac{50H_{pr}(f)V_{DM}/50}{V_{DM}/2} \right| = |2H_{pr}(f)|. \quad (2)$$

Therefore, the calibration procedure removes the factor $2H_{pr}(f)$, and the relationship between $|S_{21}|$ and the common-mode current I_{CM} is given by

$$|S_{21}| = \left| \frac{50I_{CM}}{V_{DM}} \right|. \quad (3)$$

This is used to compare between the experimental and numerical results.

The input impedance $|Z_{in}|$ and $|S_{21}|$ of the EM1 antenna with FDTD modeling and measurements are compared in Fig. 3 and 4, respectively. The agreement is good over the considered frequency range. In Fig. 4, the two peaks on S_{21} are observed at approximately 180 and 350 MHz, where the $|Z_{in}|$ is a minimum. These frequencies are related to the total length of EM1 antenna, which is similar to $X/4$ and $X/2$.

EM1 MODELING OF COUPLING TO I/O LINES

The coupling between two closely-spaced transmission lines is modeled by using a combination of multiple lumped element section modeling on the PCB, and FDTD modeling of the EM1 antenna. The lumped element modeling is compatible with general circuit analysis tools, such as SPICE. The line loss and terminations of the lines can be incorporated into the lumped element models. The cable attached to the I/O line is modeled as an EM1 antenna shown in Fig. 1(a). The input impedance of this antenna is obtained by measurements or FDTD modeling mentioned above, as shown in Fig. 2(a). Then the input impedance is used as the load in the I/O coupled line circuit modeling. The coupled noise voltage at the load of the I/O circuit is calculated with SPICE. The EM1 radiation from the attached cable is dependent on this noise voltage and the input impedance of the attached cable. Then, using FDTD modeling, the common-mode current is calculated by using the effective noise voltage calculated from the coupled-line problem to drive the EM1 antenna.

Figure 5 shows the geometry of the coupling to an I/O line problem. Two microstrip lines are located on the top of a 12 cm x 5 cm PCB. The bottom side of the PCB is the ground plane. One microstrip line is driven by the network analyzer to simulate a digital line, and the other line is the coupled I/O line, which is connected to a 20 cm long thin wire, 65 mils. in diameter. The distance between the two lines is 16.5 mils., and the line width is 13 mils. The length of the coupled line section is 3 cm.

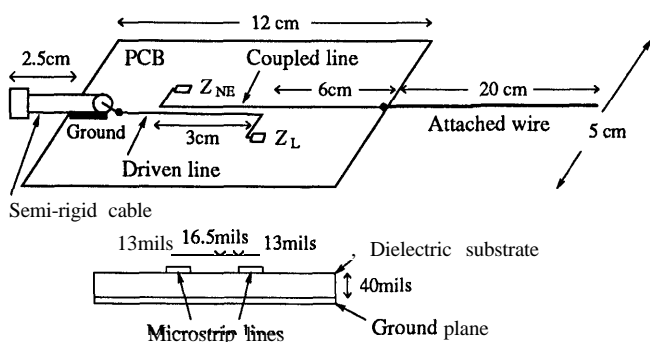

Figure 5: Geometry of the EM1 antenna driven by coupling to an I/O line.

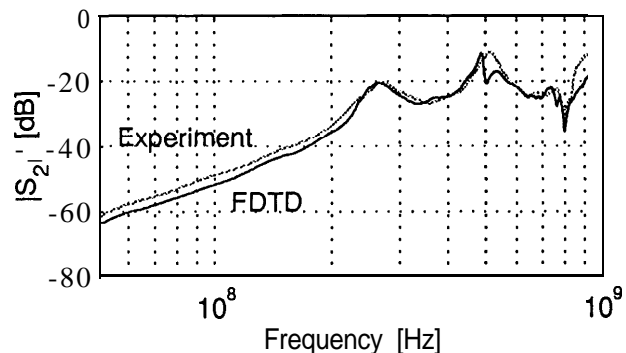

Figure 6: $|S_{21}|$ of the EM1 antenna model coupled to I/O line with FDTD modeling and measurement ($Z_{NE} = Z_L = \infty$).

In Fig. 5, Z_{NE} and Z_L are the terminated loads of the two lines.

The measurement of $|S_{21}|$ was made with the same method mentioned above, as shown in Fig. 2(b). $|S_{21}|$ of the EM1 from a coupled I/O line with FDTD modeling and measurement, in the case where $Z_{NE} = Z_L = \infty$, is compared in Fig. 6. The agreement is good over the considered frequency range.

MODELING OF EM1 ANTENNA WITH A MICRO STRIP LINE

The modeling of a PCB type EM1 antenna driven by a microstrip line, and the effect of the position of the line with respect to the board edge was also considered.

Figure 7 shows the geometry of the EM1 antenna driven by a microstrip line as a result of the finite impedance of the ground. A microstrip line, with width w of 20 mils. and length of 5 cm, was traced on the PCB and terminated by an SMT resistor. A 20 cm thin wire, 0.06 cm in diameter, was attached to the edge of a 10 cm x 15 cm PCB, with thickness $h = 43$ mils., and $w/h \approx 1/2$. A 0.085" semi-rigid cable was connected to the microstrip line. The other edge of the cable was extended beyond the PCB for 3 cm, soldered on the ground plane side of the PCB, and connected to an SMA connector.

Five different configurations with different distance d between the microstrip line and the edge of PCB, as shown in Table 1, were prepared. The characteristic impedance of strip line was approximately calculated as 100Ω [4][5], but the terminating resistor was determined from TDR measurements, as shown in Table 1.

The measurement of $|S_{21}|$ was made with the same method discussed above, as shown in Fig. 2(b). Figure 8 shows the experimental results of $|S_{21}|$. The first peak is at approximately 260 MHz, and is related to the total length of the EM1 antenna, which is comparable to $X/4$. As the position of the microstrip line is closer to the edge

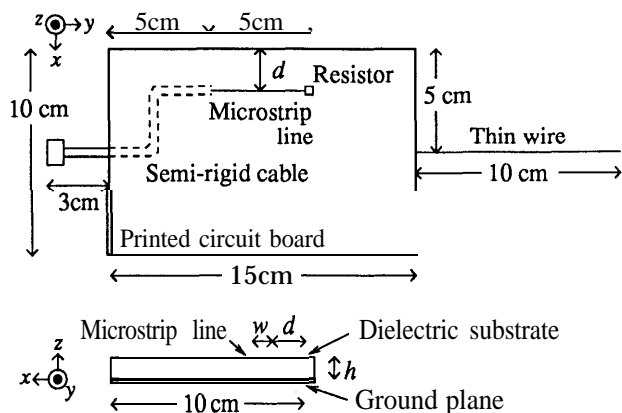

Figure 7: Geometry of the PCB type EM1 antenna driven a microstrip line.

Table 1: The EM1 antenna with a micro strip line under test (d : distance between the strip line and the edge of PCB, h : thickness of the dielectric substrate).

	d	d/h	Terminating resistor
d50	50 mils	1.1	100 Ω
d250	250 mils	5.8	100 Ω
d400	400 mils	9.3	91 Ω
d600	600 mils	13.9	91 Ω
center	4.97 cm	45.5	91 Ω

of the PCB, $|S_{21}|$ becomes larger. The difference between on the case of “d50” and “d250” is approximately 7 dB. The results suggest that $d/h > 10$ may be most suitable in the design of traces on a PCB.

FDTD modeling of a PCB type EM1 antenna with a microstrip line was also attempted. Though the width of microstrip line and the depth of the dielectric substrate are very thin, each must be modeled with at least 3 cells in the calculation. The cell sizes are then $\delta x = 0.17$ mm, $\delta y = 1.2$ mm and $\delta z = 0.36$ mm. Then, the dimension of the EM1 antenna model is 603 x 200 x 18 cells, in the x , y , and z dimensions. And the time step is $\delta t = 4.23E - 13$ s from Eq. (1). Also, more than 20,000 time steps are needed to calculate over the considered frequency range from 50 MHz to 1 GHz, though Prony’s method or the generalized pencil of function (GPOF) can reduce this [3]. Presently too much memory and time are needed for this numerical calculation in the present FDTD code. A multi-grid technique is proposed to reduce the mesh cell size, and is currently being implemented in the FDTD code [6].

CONCLUSION

FDTD modeling of EM1 antennas can be used to develop insight and design guidelines for high-speed digital

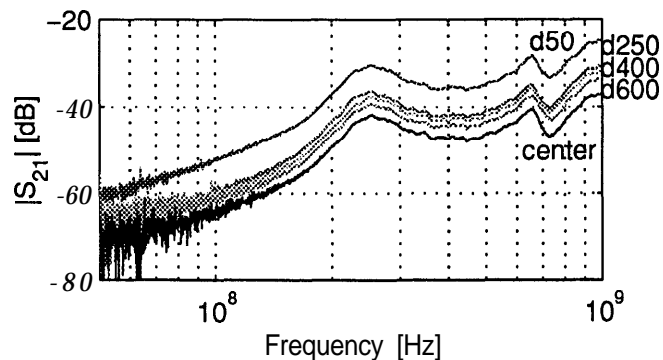

Figure 8: $|S_{21}|$ of the PCB type EM1 antenna with a micro strip line.

designs. Measurements of input impedance and common-mode current were used to demonstrate the modeling. Specific applications of the modeling include a hybrid transmission line and FDTD for modeling EM1 resulting from high-speed digital and I/O line coupling. Other cases require a full FDTD implementation of the geometry on the PCB to capture the EM1 mechanism, such as the finite impedance of the ground plane, which impacts the proximity of a trace to the board edge and the resulting EM1. In these cases, the FDTD problem can become prohibitively large, and alternatives such as multi-gridding are necessary. However, when FDTD can be used to EM1 modeling, general design guidelines can be developed, as well as insight into fundamental EM1 mechanisms gained.

REFERENCES

- [1] D.M. Hockanson, J.L. Drewniak, T.H. Hubing and T.P. VanDoren, “FDTD Modeling of common-mode radiation from cables”, *IEEE Trans. on EMC*, vol.38, no.3, pp.376-387 (1996).
- [2] D.M. Hockanson, J.L. Drewniak, T.H. Hubing, T.P. Van Doren, F.Sha and M.J. Wilhelm, “Investigation of Fundamental EM1 Source Mechanisms Driving Common-Mode Radiation from Printed Circuit Boards with Attached Cables”, *IEEE Trans. on EMC*, vol.38, no.4, pp.557-576 (1996).
- [3] A. Taflove, *Computational Electrodynamics : The Finite-Domain Time-Domain Method*, Norwood, Artech House (1995).
- [4] T. Edwards, Foundation for *Microstrip Circuit Design*, New York, John Wiley & Sons (1992).
- [5] D.M. Pozer, *Microwave Engineering*, New York, John Wiley & Sons (1998).
- [6] D.T. Prescott and N.V. Shuley, “A Method for Incorporating Different Sized Cells into the Finite-Difference Time-Domain Analysis Technique”, *IEEE Microwave & Guided Wave Letters*, vol.2, no.11, pp.434-436 (1992).